

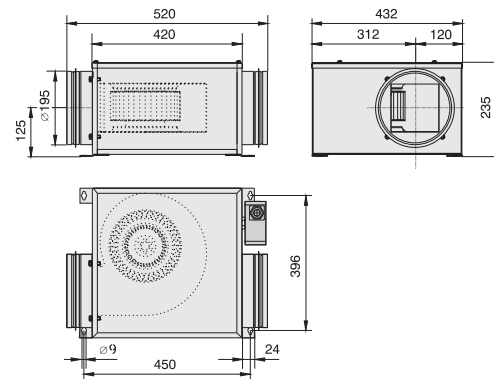

Typ / Type : Z 200 U		Art.-Nr. / Art.-No. : F05-20015	
U	230V (50Hz)	$\Delta p_{fa \text{ min}}$	-- Pa
P ₁	0.15 kW	ΔI	-- %
I _N	0.68 A	I _A / I _N	1.5
n	1210 min ⁻¹		IP44
C _{400V}	4 μF		01.009
t _R	55 °C		13 kg



LWA _{rel} A-bewertet bei V=0,5*V _{max} LWA _{rel} A-weighted at V=0,5*V _{max}	fM [Hz]						
	125	250	500	1K	2K	4K	8K
LWA ₂ [dB(A)] Gehäuse / casing	40	38	35	34	33	29	23
LWA ₅ [dB(A)] Ansaugseite / inlet side	39	41	40	39	38	36	31
LWA ₆ [dB(A)] Ausblasseite / outlet side	45	54	57	63	64	59	53